

XAMControl

12.11.2021

Dominik Riegelnegg



- Kommunikation
- Datenaustausch
- Einbindung des Reglers

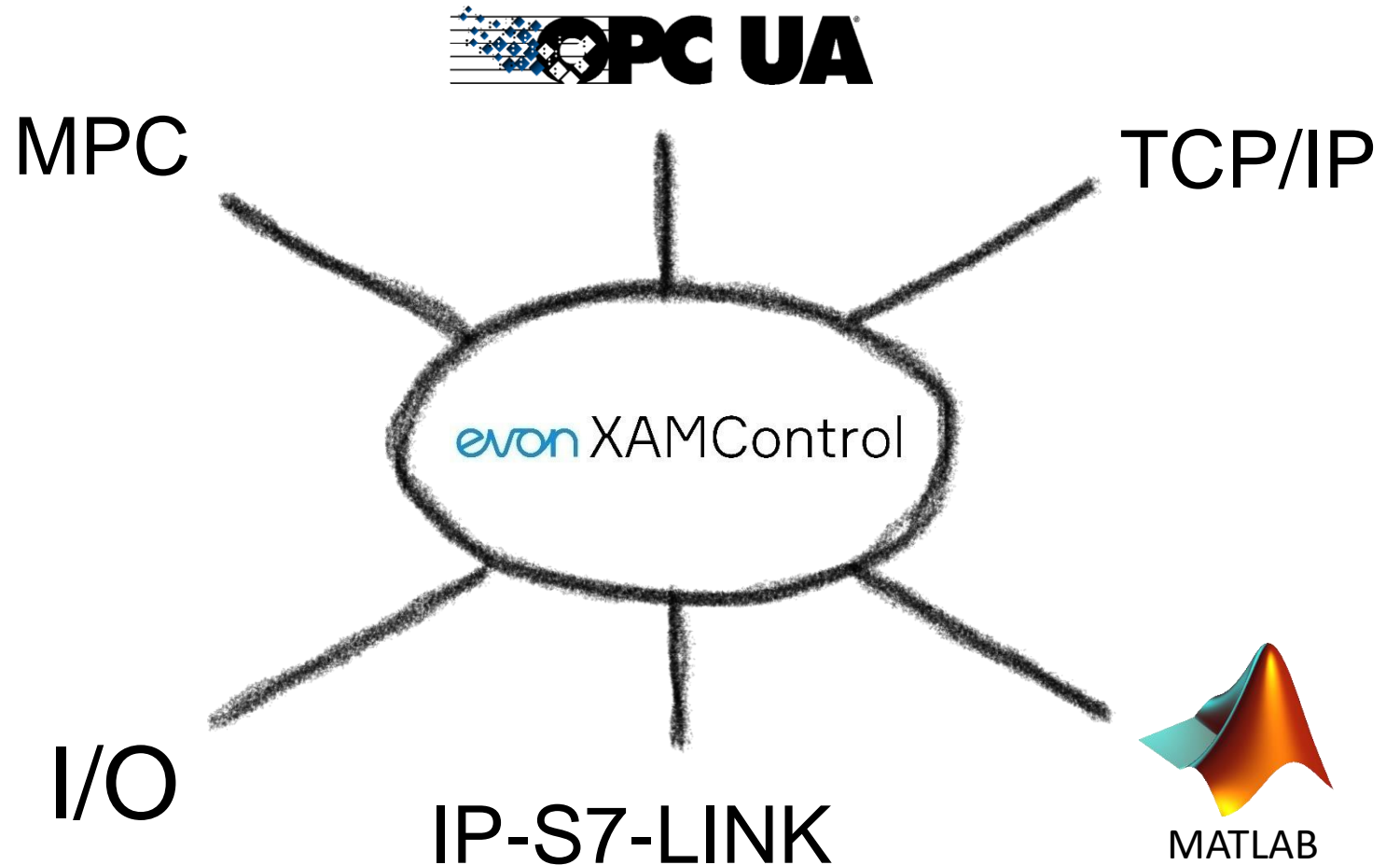

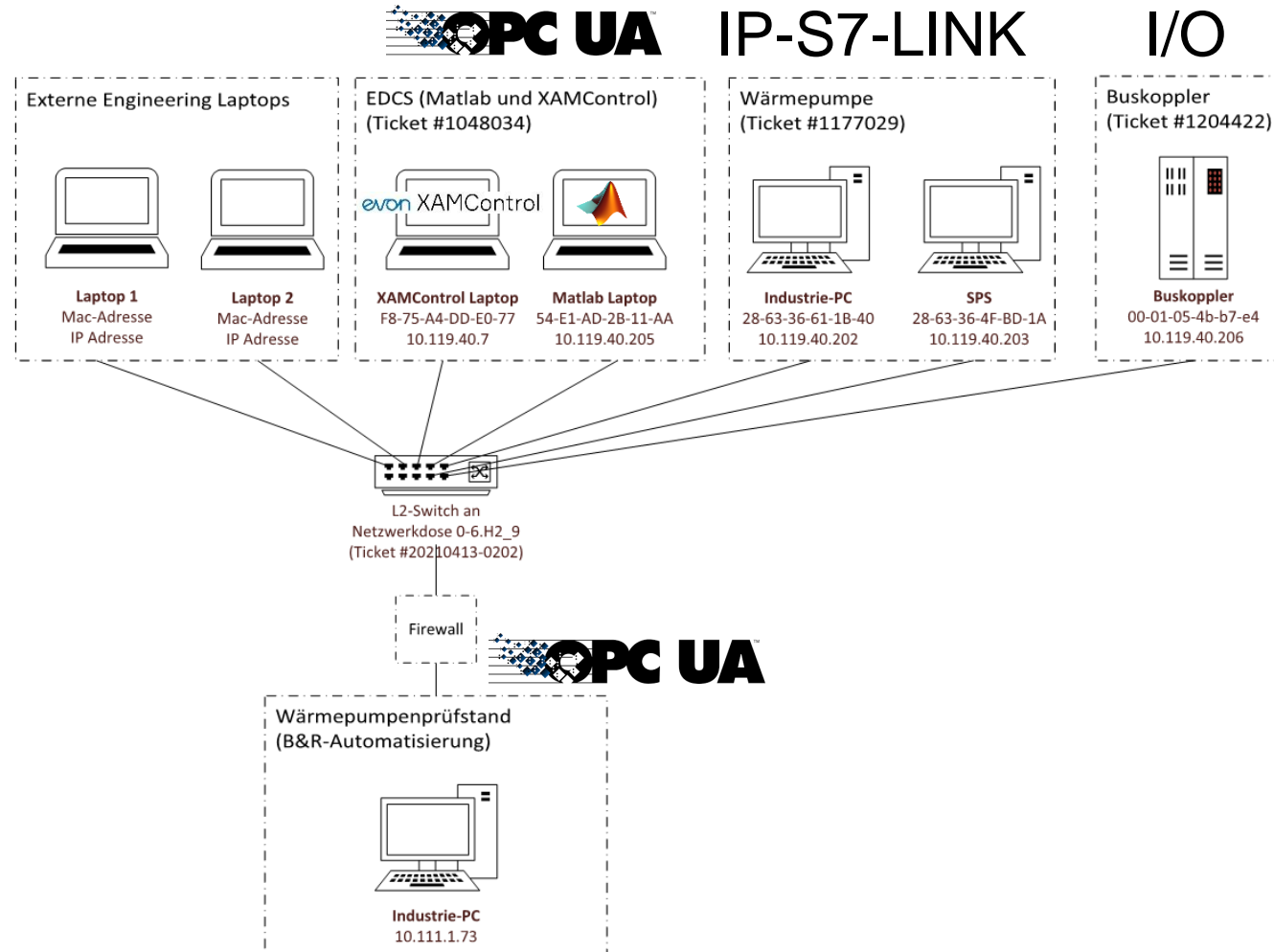

LABORSCHEMA

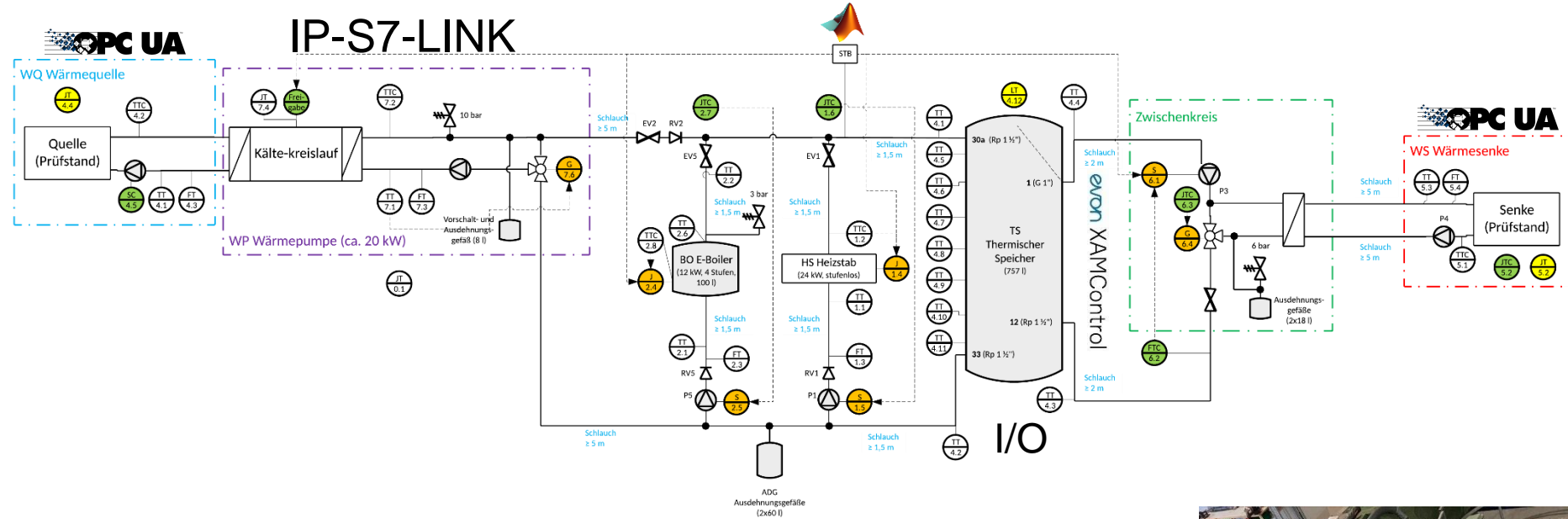



Wärmequelle

TTC 4.2

Sollwertvorgabe:

EDCS Manuell

SC 4.5

Sollwertvorgabe:

EDCS Manuell

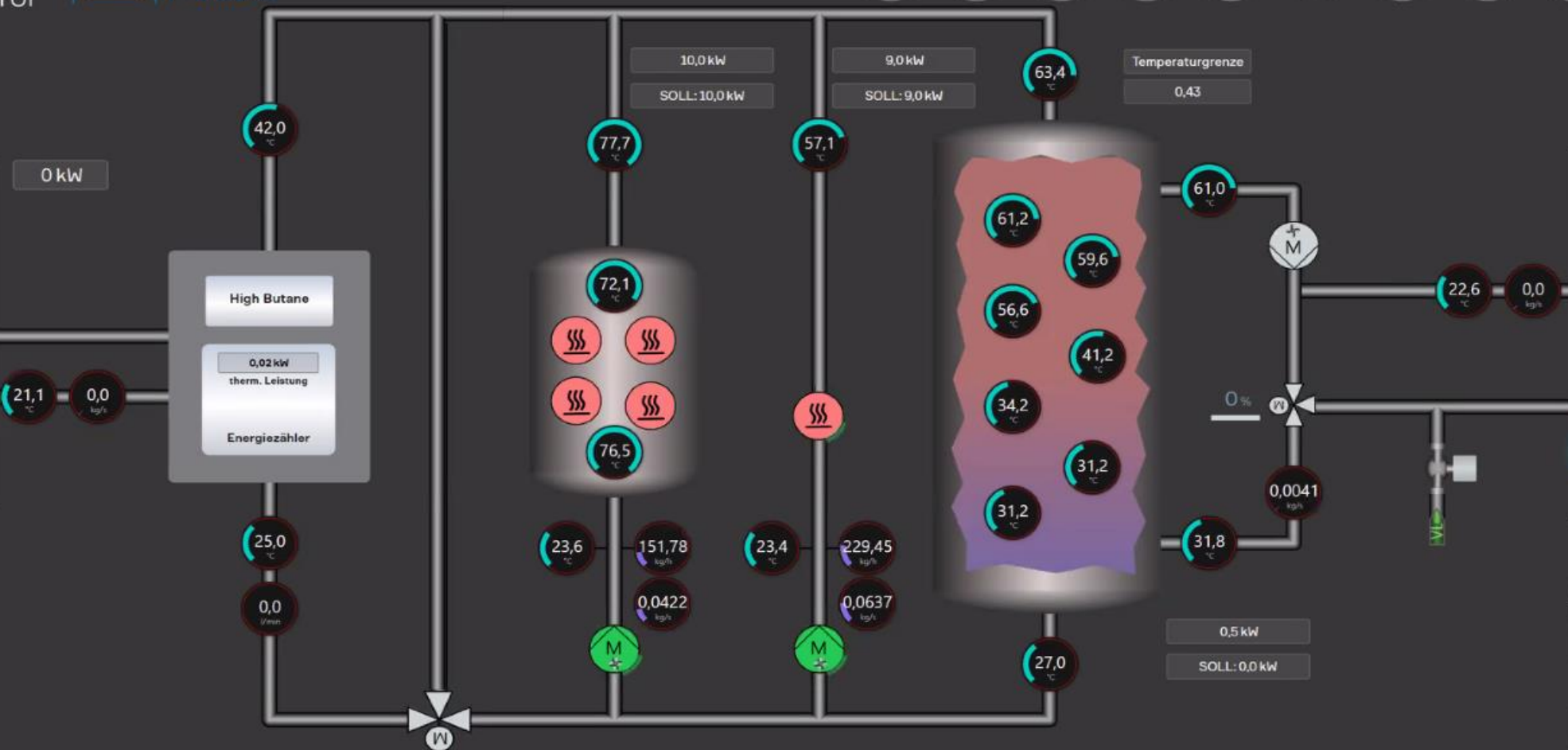

Wärmesenke

TTC 5.1

Sollwertvorgabe:

EDCS Manuell

JTC 5.2

Sollwertvorgabe:

EDCS Manuell

REGLER

Anlagenkennzeichnung

EDCS-Betrieb

Labor Wirkleistung

Regelung Heizstab | **Regelung Boiler** | Regelung Mischventil

Anlage EIN

Sollwertvorgabe:

Pumpe: EDCS Manuell

Istwert 57,1 °C

Sollwert 78,0 °C

Stellgröße -2,0 %

Sollwertvorgabe:

Wärmestromregler: EDCS Manuell

Istwert 9,0 kW

Sollwert 9,0 kW

Stellgröße 0,0 %

Therm. Leistung



| Name | Bemerkung | Wert | Min | Max | Durchschnitt | Dim | Y Min | Y Max | Sichtbar | Skala anzei... | Autoskali... | Zeit |
|------------------|---|------|-------|---------|--------------|-----|-------|-------|-------------------------------------|-------------------------------------|--------------------------|-------------------------|
| J12_7 PowerTherm | Thermische Leistung Boiler: Thermische Leistung | | 0,000 | 113,756 | 7,542 | | 0 | 30 | <input checked="" type="checkbox"/> | <input checked="" type="checkbox"/> | <input type="checkbox"/> | 03.05.2021 17:03:31,600 |

DIE SOFTWARE PLATTFORM

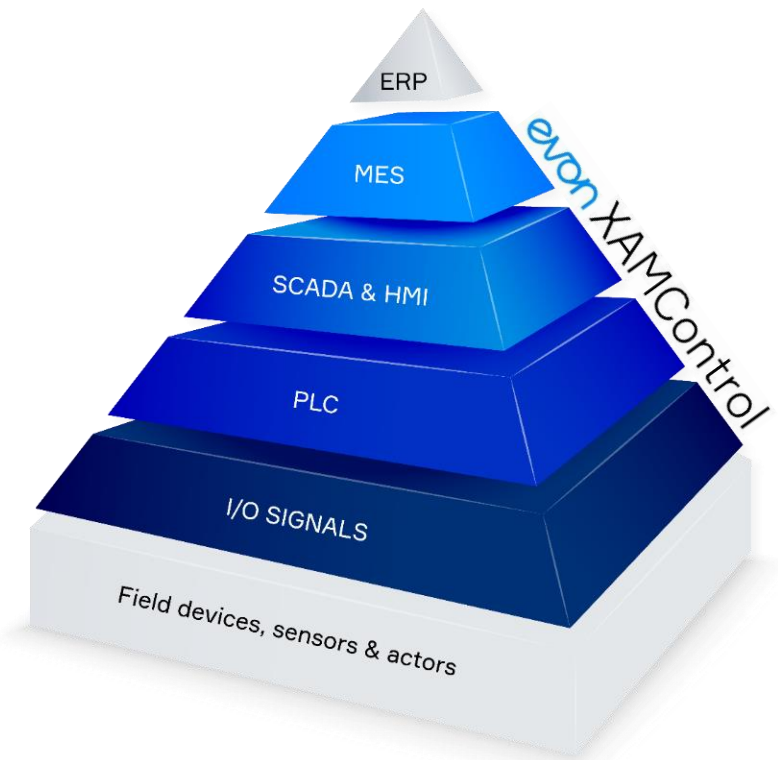
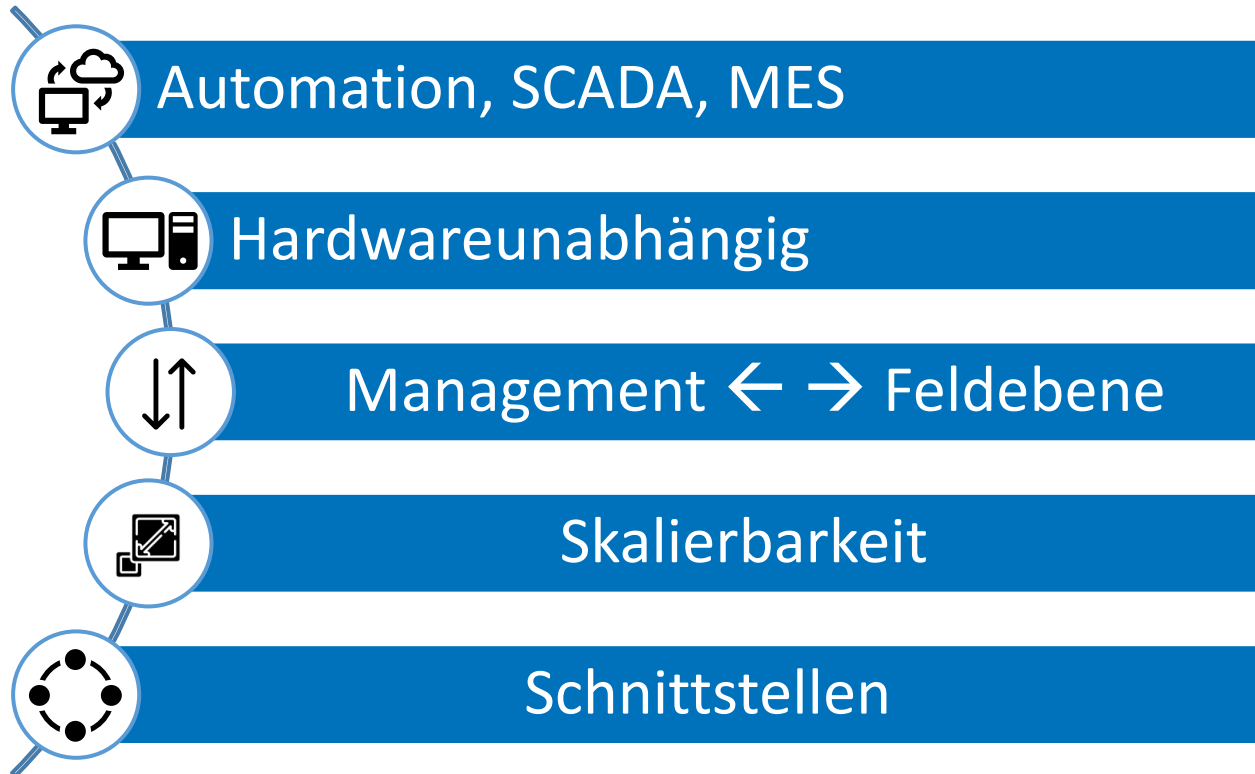

ÜBER XAMCONTROL



| Bedienung <input checked="" type="checkbox"/> | | | Entwicklung <input checked="" type="checkbox"/> | | Features | |
|---|-------------------------------|-----------------|---|-----------------------|-----------------------|--|
| Visualisierung & Bedienung | Trend & historische Datenbank | User Management | Entwicklungs umgebung | PLC & Business logics | Web-Server | Helpdesk & Infocenter |
| Alarme & Meldungen | Reports & Statistiken | Dashboards | Schnittstellen & Protokolle | ACC - Bibliothek | Dokumenten Management | MPC & Algorithmen <input type="checkbox"/> |

XAMControl



REFERENZEN

Referenzberichte:

<https://evon-automation.com/success-stories/>

YouTube – Was ist evon XAMControl:

https://www.youtube.com/watch?v=_weDrlzumXY

YouTube - Visualisierung und Bedienung | evon XAMControl:

<https://www.youtube.com/watch?v=hy0A2KWCM9E>

evon GmbH

Wollsdorf 154
8181 St. Ruprecht an der Raab
AUSTRIA

www.evon-automation.com



Dominik Riegelneegg

dominik.riegelneegg@evon-automation.com

+43 (0) 3178 21800 - 183



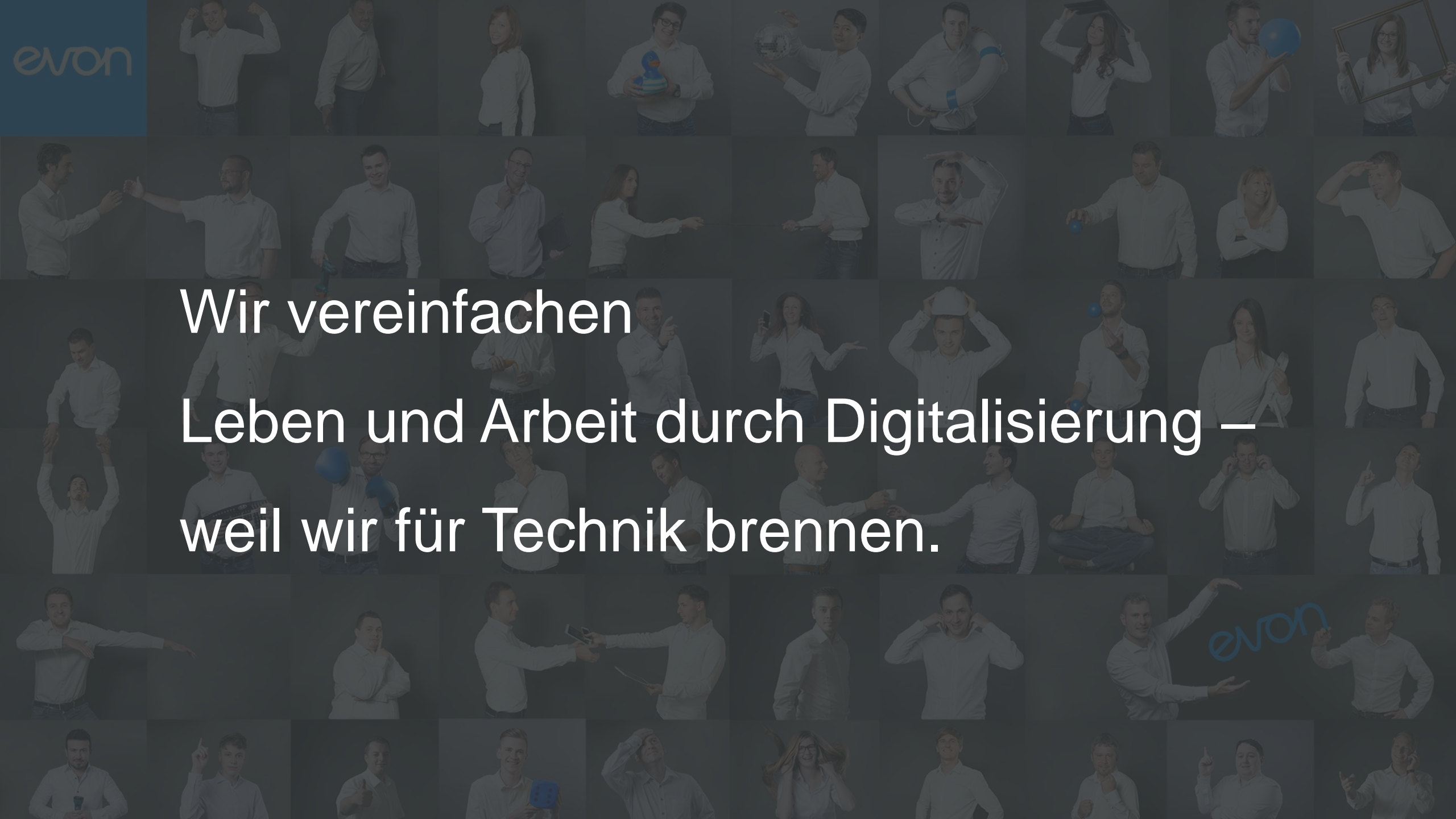

Wir vereinfachen
Leben und Arbeit durch Digitalisierung –
weil wir für Technik brennen.